

Microstrip Phase Array Antenna



Performed By: Jerry Crandal, Huy Nguyen and Vishal Bhavsar

Advising Professor: Dr. Balandin, Dr. Giles



Project Objectives

- To design and build a phase array antenna with a steerable radiation pattern
- To complete the project without exceeding the budget
- To gain valuable engineering experience in research and design



Approach

- One-dimensional array of microstrip elements
- 4 elements with $d = \frac{\lambda}{2}$
- Rectangular patches as array elements
- Received signal of each element is delayed in order to change its phase
- Consecutive phase shift

Benefits of Microstrip Antennas

- Easy to manufacture
- Fairly inexpensive
- Extremely low profile
- Very useful for:
 - radar applications
 - satellite communications
 - missile guidance

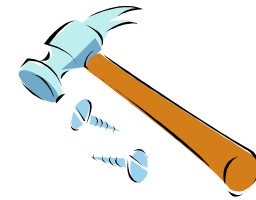



Theory

- Steers the radiation pattern without physically moving the antenna
- Greater directivity
- Increases signal to noise ratio
- Radiation pattern is governed by *Array Factor* (AF)
where $X = \beta_0 d \cos\phi - \psi$
- $E(\theta, \text{total}) = E(\theta, \text{single element}) \times \text{Array Factor}$

$$AF = \frac{\sin(N \times X / 2)}{\sin(X / 2)}$$



Patch Dimensions

- $L = 1 / (2 / \lambda \times (\epsilon_{\text{reff}})^{1/2}) - 2\kappa L$
- $\kappa L = 0.412h \times ((\epsilon_{\text{reff}} + 0.3)(W/h + .264)) / ((\epsilon_{\text{reff}} - 0.258)(W/h + 0.8))$
- $W = c / (2 \times f_0) \times (2 / (\epsilon_r + 1))^{1/2}$



Feed Point

- $G_1 = (-2 + \cos(X) + X \times S_i(X) + \sin(X)/X)/(120 \times \pi^2)$
- $G_{12} = 1/(120\pi^2) \left[\int_0^\pi \frac{\sin(X/2 \times \cos(\theta))}{\cos(\theta)} J_0 2\pi L/\lambda \right. \\ \left. * \sin(\theta)^4 d\theta \right]$
- $R_p = 1/(2 \times (G_1 + G_{12}))$
- $y_0 = L/\pi \times \cos^{-1}((Rin/Rp)^{1/2})$

Fringing

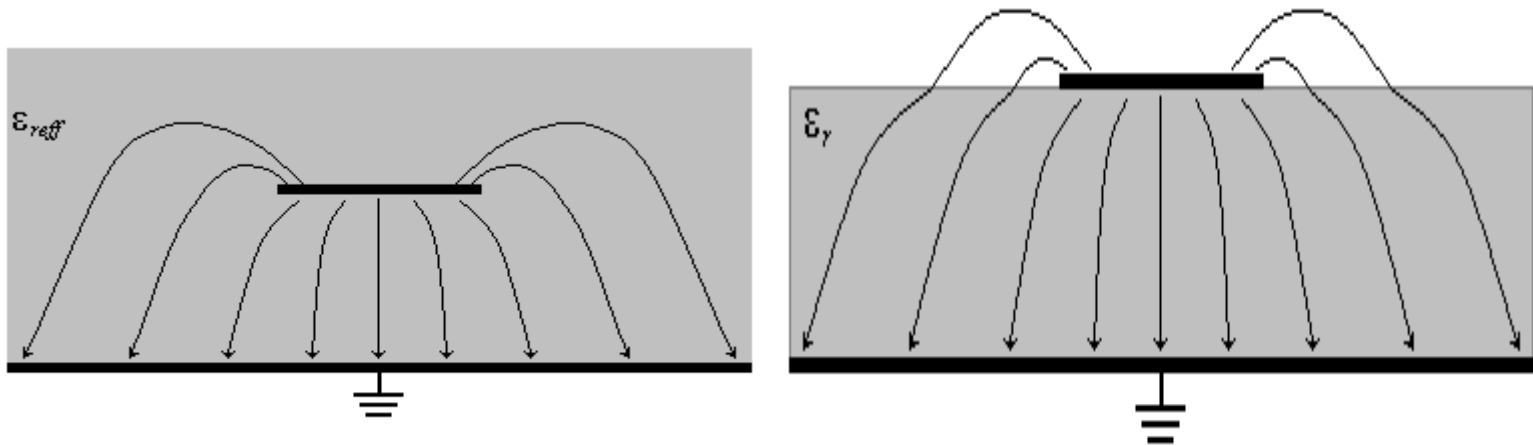

$$\epsilon_{\text{reff}} = (\epsilon_r + 1)/2 + (\epsilon_r - 1)/2 \times (1 + 12 \times h/W)^{-1/2}$$



Block Diagram

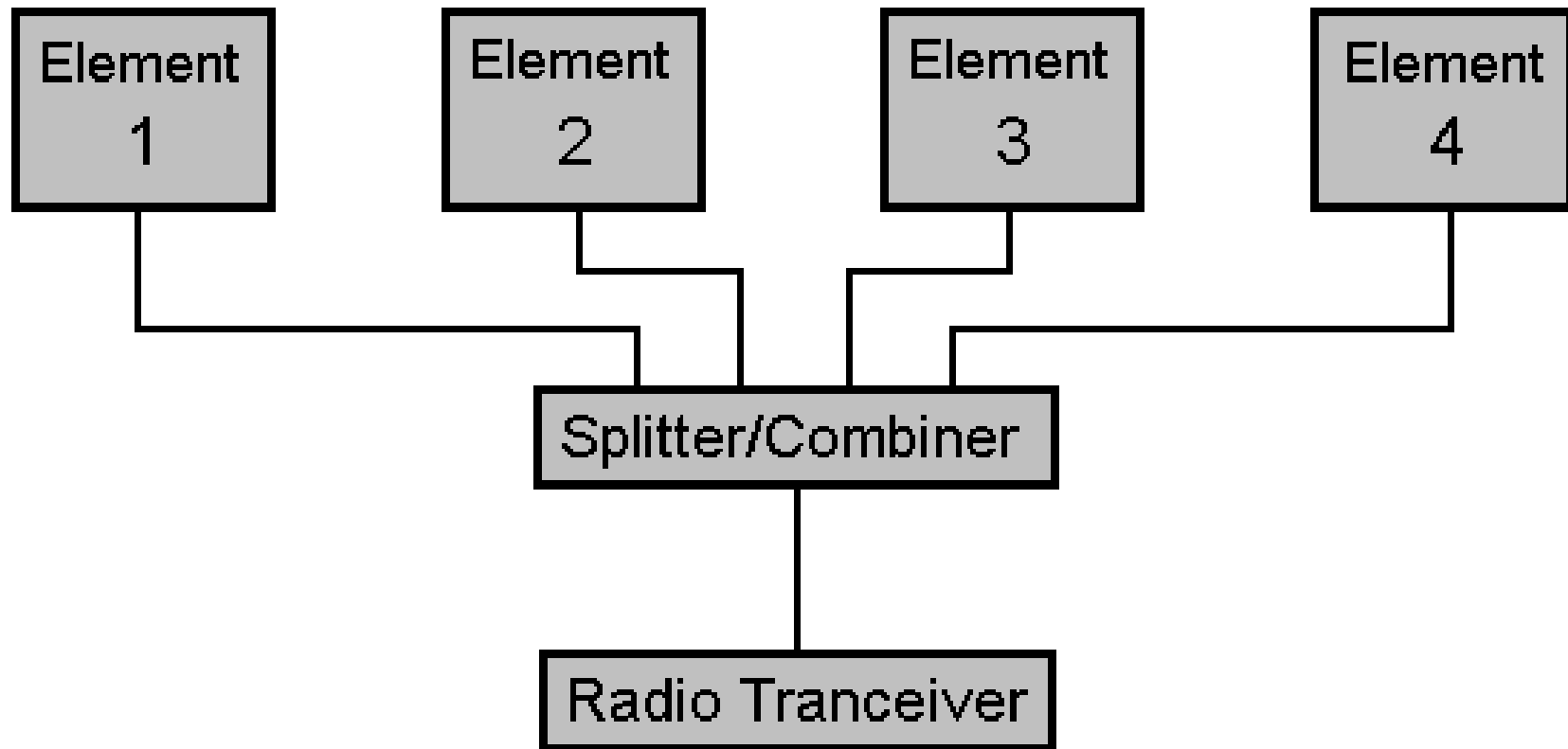

Phase Relationship

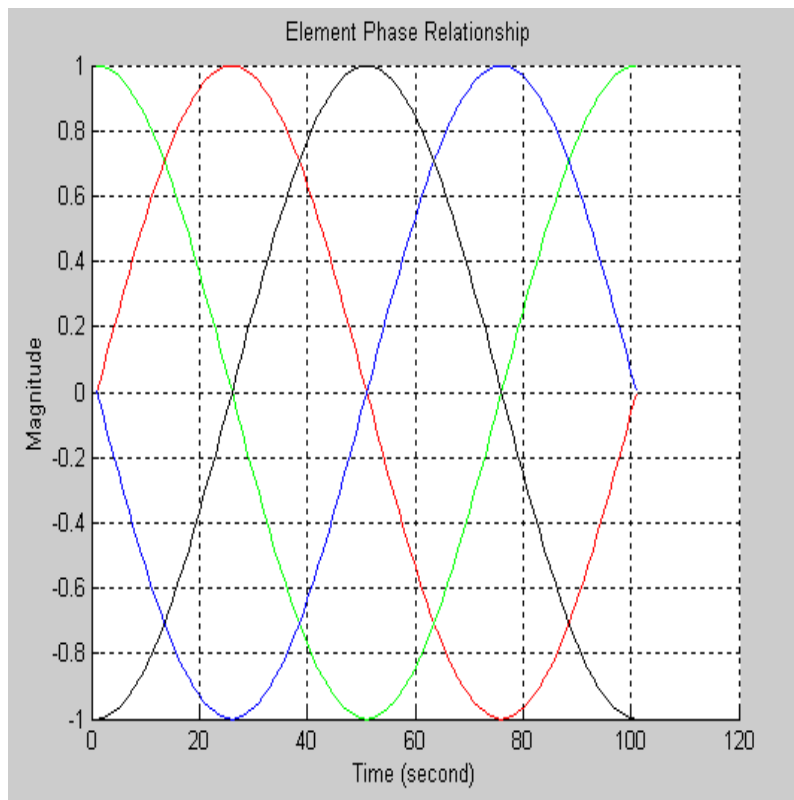

- Element 1 = 0 rad
- Element 2 = $\text{Pi}/2$ rad
- Element 3 = Pi rad
- Element 4 = $3 \cdot \text{Pi}/2$ rad

Phase Shifting

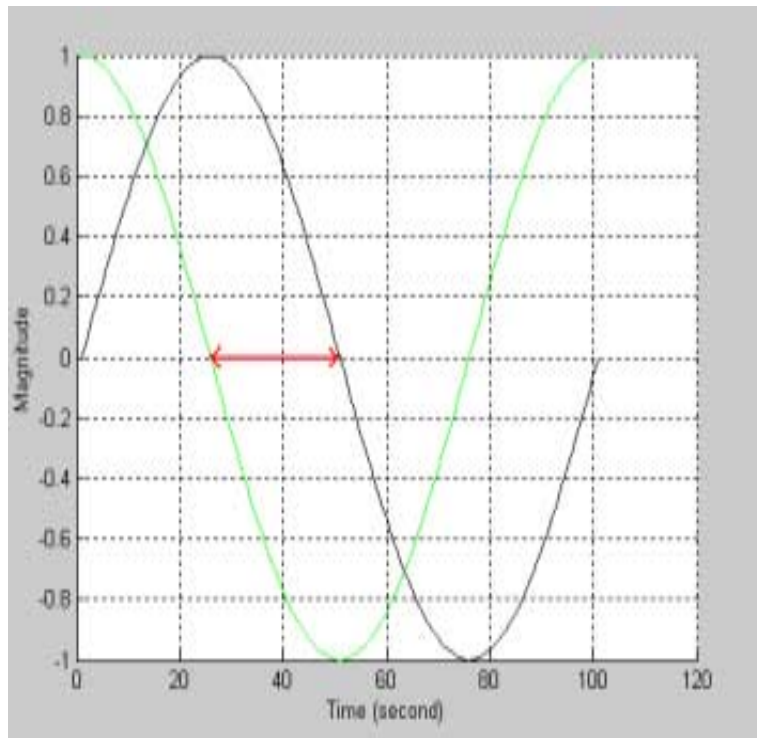

$$\sin(\omega t_1 + \phi_1) = 0$$

$$\sin(\omega t_2 + \phi_2) = 0$$

$$\omega(t_1 - t_2) + \phi_1 - \phi_2 = 0$$

$$\omega(-t_2) + \Delta\phi = 0$$

$$t_2 = \frac{\Delta\phi}{\omega}$$

$$CoaxLength = c * vel.fact. * \frac{\Delta\phi}{2\pi f}$$

Coaxial Length

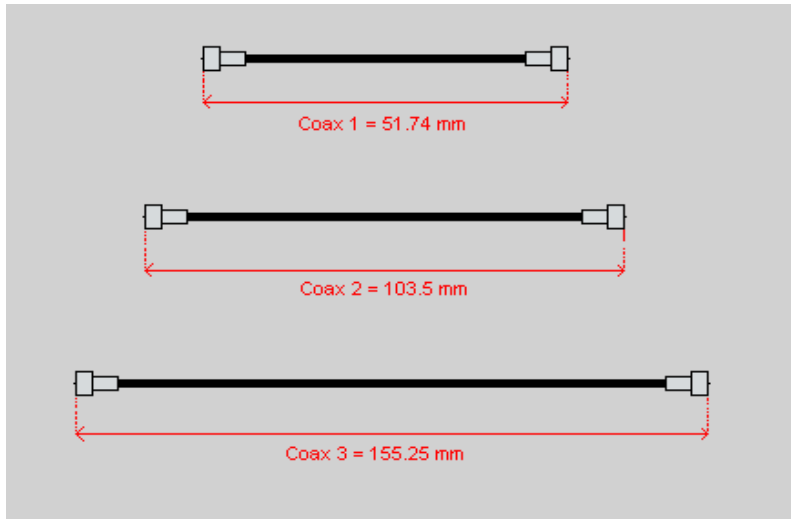

Coax 1 = $\text{Pi}/2$ rad

Coax 2 = Pi rad

Coax 3 = $3 * \text{Pi}/2$ rad



Construction

- PC board was cut and milled
- Holes for coaxial connectors were drilled
- Coaxial signal wires were soldered to feed points
- Wood for frame was cut and assembled
- Holes for U-bolts were drilled

Testing Procedure

- Adjust radio receiver to 917.88 MHz
- Set phase angle to 0 or 90 degrees
- Rotate phase array in increments of 11.25 degrees
- Adjust inline attenuator for equivalent gain



Radiation Pattern Of The Array Factor (Theoretical)

$$\psi = 0^\circ$$

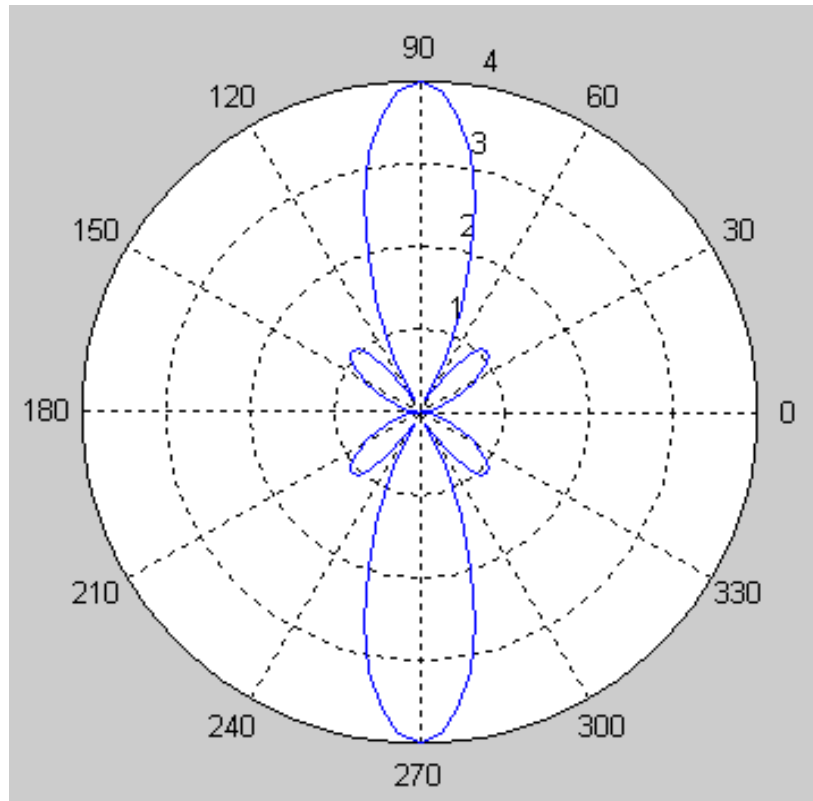

$$\psi = 90^\circ$$

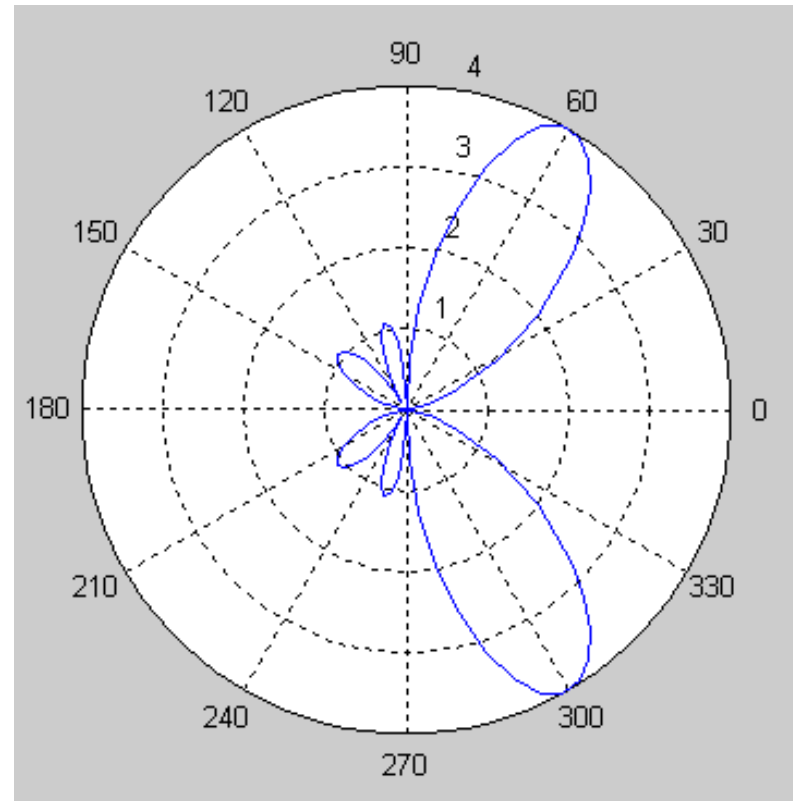

Theoretical Results Vs. Experimental Results Of Single Element

Theoretical

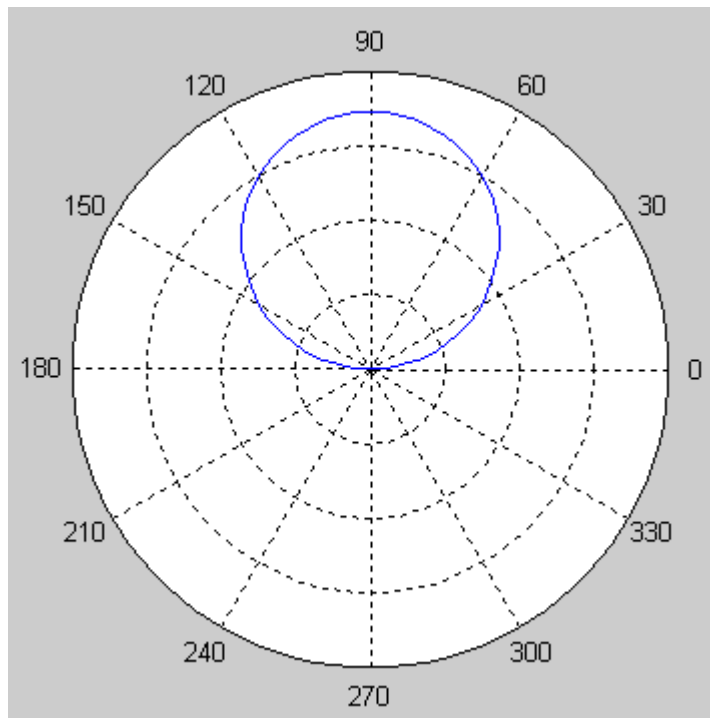

Experimental

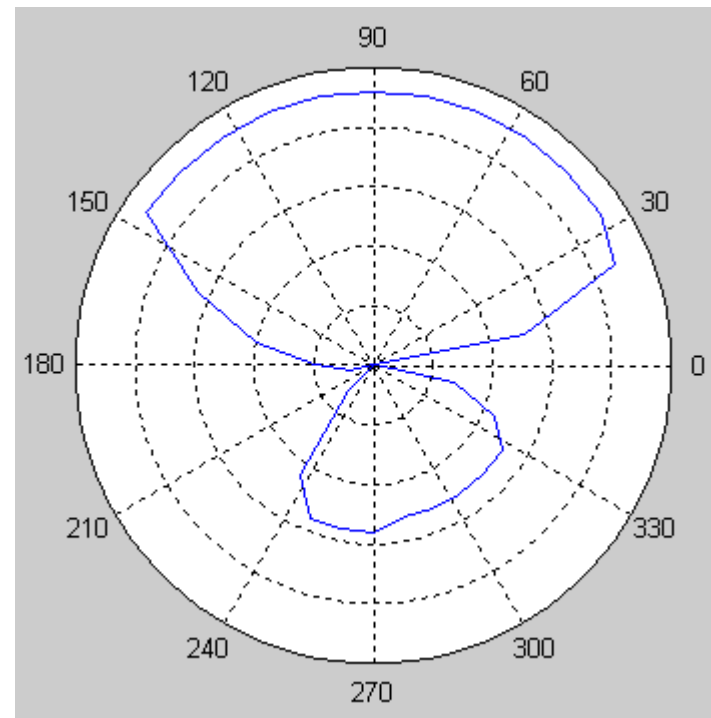

Theoretical Results Vs. Experimental Results Of Array (0° phase shift)

Theoretical

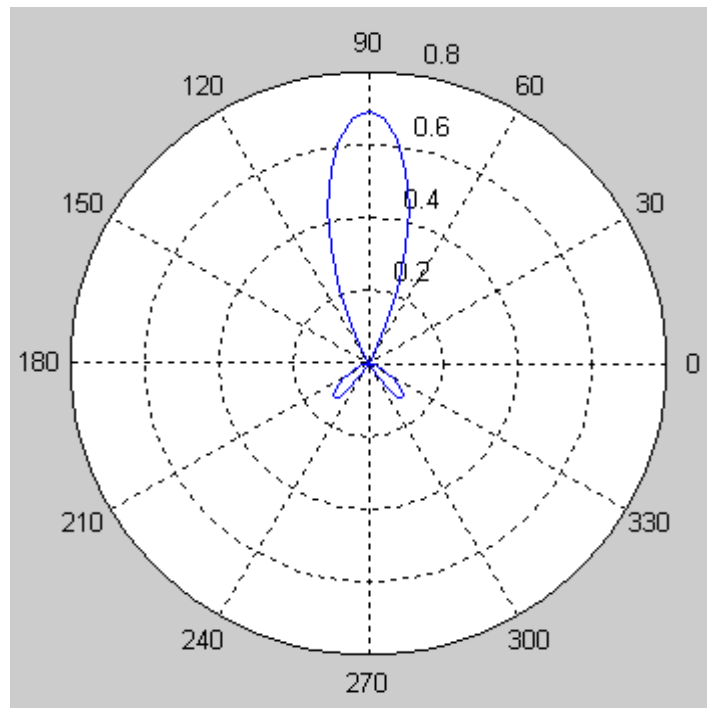

Experimental

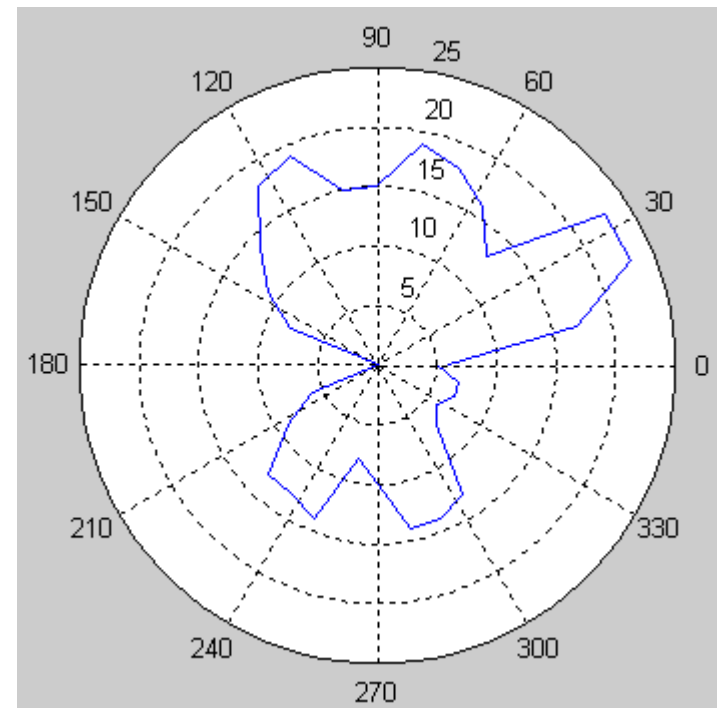

Theoretical Results Vs. Experimental Results Of Array (90° Phase Shift)

Theoretical

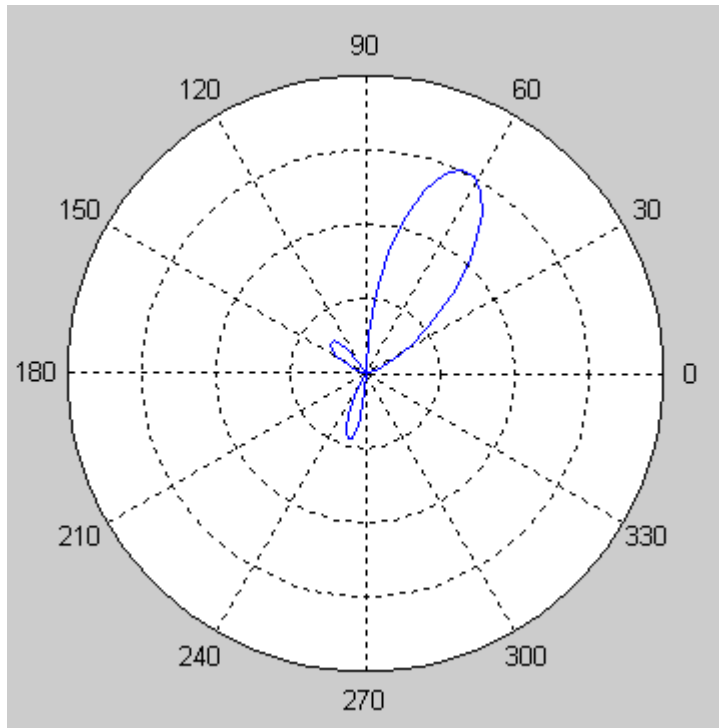

Experimental

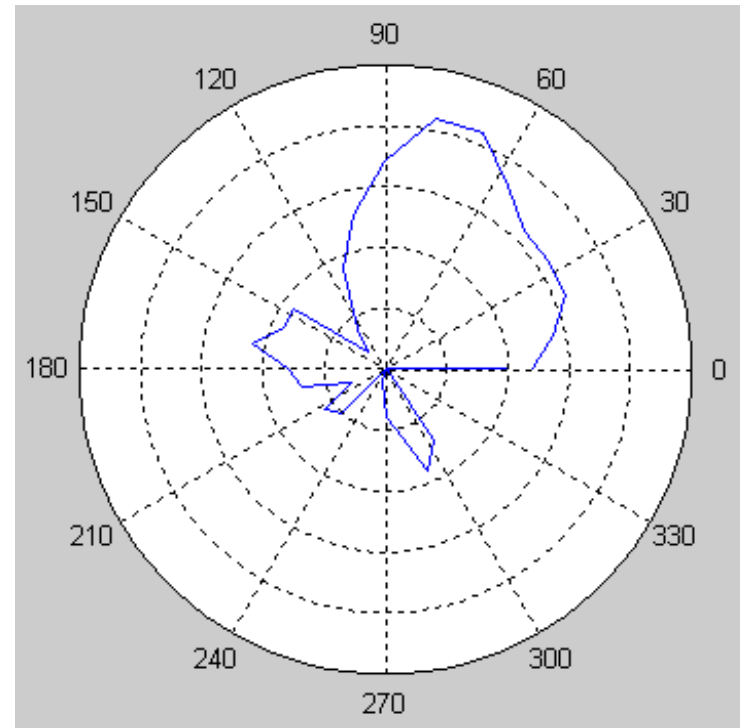

Budget

■ PC board:	\$ 42.25
■ Coaxial cables:	\$ 6.40
■ Connectors:	\$ 12.47
■ Adaptor:	\$ 3.49
■ Reducer:	\$ 4.47
■ Pine wood:	\$ 6.49
■ U-bolts:	\$ 4.38
■ Miscellaneous:	\$ 17.12
■ Total:	\$ 97.07

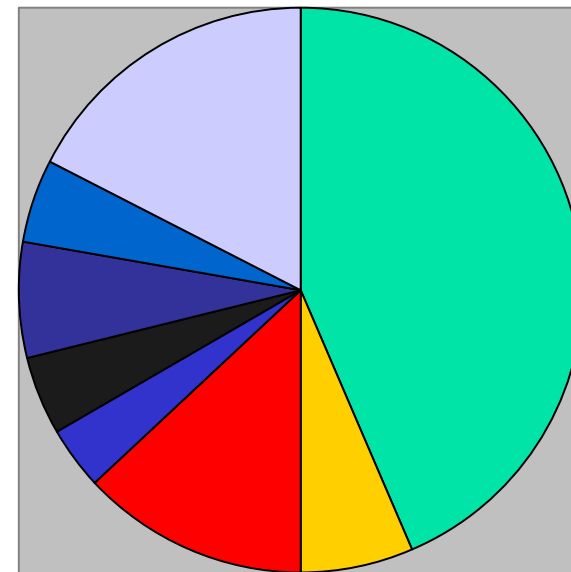

■	PC board
■	Coaxial cables
■	Connectors
■	Adaptor
■	Reducer
■	Pine wood
■	U-bolts
■	Miscellaneous



Project Improvement

- Impedance Matching
- Relay Switching
- Microstrip Feed Line

Microstrip Phase Array Antenna



The End

Questions ?

